

SMAC Controller

Industrial Lubrication Systems



Operation

The SMAC Controller is a multi-purpose programmable controller used with industrial lubrication systems. Controller settings are saved whenever power is interrupted. Up to four operating modes can be selected which allows the controller to be used with various lubrication system designs. The controller is available in both 110 and 220/230 VAC service.

Features

- + Digital status display on front cover for easy programming
- + System monitoring capabilities
- + Data memory function initiated at power down
- + Compact design



Technical Data

Operating Voltage	110 VAC, 220/230 VAC (50/60 Hz)
IP Enclosure Rating	IP-55 (Liquid tight connector)
Fault Relay Contacts	30 W (220/230 VAC)
Ambient Temperature	-4°F to 131°F (-20°C to 55°C)
Weight	0.3 kg
Electrical Fuse	3 amp (110 VAC) 2 amp (220/230 VAC)

Controller Status LEDs

Red Steady	Lubrication cycle
Yellow Steady	Alarm
Green Steady	Power supply on
None Lit	No input power to controller

Installation

- + Mount the controller in a clean area with easy access for programming and visual checking.
- + Mount controller on a flat surface.

How to Order

Name	Description	Part #
SMAC Controller	Controller with liquid tight connector (110 VAC)	22361-E2
	Controller with liquid tight connector (220/230 VAC)	22361-E1

When ordering, specify by name, description and part number, e.g. SMAC Controller with liquid tight connector (110 VAC), Part #22361-E2.

Accessories

Description		Part #
Replacement Fuse	3 amp, 110 VAC	31076
	2 amp, 220 VAC	31076-6

BIJUR DELIMON INTERNATIONAL

(919) 465 4448 LOCAL
(800) 631 0168 TOLL-FREE
(919) 465 0516 FAX

WWW.BIJURDELIMON.COM

2100 Gateway Centre Blvd., Suite 109
Morrisville, NC 27560

Electrical Terminal Connections

Motor Driven Lubricators

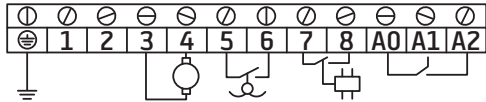

Pneumatically-activated Lubricators

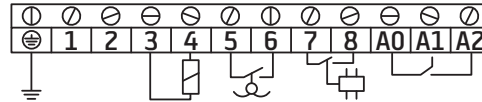

Connection #	Description
⊕	Ground
1, 2	L1 (1) and L2 (2) 110 or 220/230 VAC power supply
3, 4	Motor or solenoid valve output (110 or 220/230 VAC)
5, 6	Input- low level (closed at low level)
7, 8	Input- cycle completion Mode 2 & 4 (pressure switch) Mode 3 (cycle switch)
A0, A1, A2	Fault switch (normally open contact rating 1 amp max), NO: A0/A2, NC: A0/A1

Legend

	Ground
	Power supply (110 or 220/230 VAC)
	AC motor
	AC solenoid
	Cycle switch or pressure switch
	Low level switch (closed at low level)

Operation

Keys Description



With the controller energized:

- + Press keys **S** and **R** simultaneously and release to enter control mode.
- + The display panel will now show a fixed letter for the selected mode and a flashing number (1-4).
- + To select the required mode press the **▲** key.
- + Press the **S** key to advance to the next parameter of the selected mode.
- + Repeat steps 3 and 4 above using the **◀▶** key to move across the digits and the **▲** key to change the value of the selected flashing digit.
- + On completion, press the **R** key to save the data and initiate a lubrication cycle.

Manual Override

- + With the controller energized press the **R** key to initiate a lubrication cycle.

Program Review

- + To review the preset data, press the **S** key repeatedly with the controller energized.
- + To return to operating condition display, release **S** key or depress **S** key for 5 seconds.

Fault Alarm

- + In any alarm condition, e.g. low level, low pressure etc., the pump will not be able to operate and the alarm lamp will illuminate. The fault condition must be rectified to cancel the alarm and reactivate the system.

BIJUR DELIMON INTERNATIONAL

(919) 465 4448 LOCAL
(800) 631 0168 TOLL-FREE
(919) 465 0516 FAX

WWW.BIJURDELIMON.COM

2100 Gateway Centre Blvd., Suite 109
Morrisville, NC 27560

Operation Mode

Timer Control Mode (d 1)

Recommended for Systems without a Pressure Switch or Cycle Switch

Low level alarm function enabled*

In this mode, the lubricating system runs according to the preset run time and idle time.

Pressure Control Mode (d 2)

Recommended for Injector Systems

**Pressure switch function enabled/
Low level alarm function enabled***

A pressure switch installed downstream from the pump functions as the key monitoring device for the entire system. Normally the system will build up sufficient pressure required to activate the pressure switch (normally open) in a predetermined period of time (called monitor time) once the pump starts. The user can adjust the monitor time to a setting greater than the time required to satisfy the pressure switch (normally 1.5 times greater). If the system fails to reach sufficient pressure during that time period an alarm signal will be displayed (yellow LED on and EEPP appears on the digital readout). Possible causes for this type of alarm could be pump malfunction, broken supply line or crushed supply line prior to pressure switch. Lubrication intervals are adjustable from 1 to 9999 minutes. A four second run delay following a pressure switch closure assures adequate pressure downstream from the pump.

Cycle Control Mode (d 3)

Recommended for Progressive systems

Cycle switch function enabled/ Low level alarm function enabled*

The cycle switch mounted on a progressive divider valve is the key monitoring device for the entire system. Normally when grease is being discharged from the outlets of the divider valve, a cycle pin engages with the switch, confirming a successful lubrication cycle. The controller can be programmed to allow for a predetermined number of cycle counts (1-999). Once the preset number of counts is obtained the controller will stop the pump and revert back to the idle time setting (1-9999 minutes). If the desired number of cycle counts is not obtained within five minutes of run time (non-adjustable), an alarm signal will be displayed (yellow LED on and 000 appears on the digital readout). Possible causes for this type of alarm could be pump malfunction, divider valve malfunction, broken supply line or blocked supply line or feed line.

Pulse Control Mode (d 4)

Recommended for Pulse systems

Pressure switch function enabled/ Low level alarm function enabled*

This mode is designed for pulse systems where the pump doesn't run continuously, such as a pneumatically actuated piston pump. The controller can be programmed to initiate multiple on/off signals to a solenoid valve for frequent cycling of the pump. Cycles are monitored by a single pressure switch.

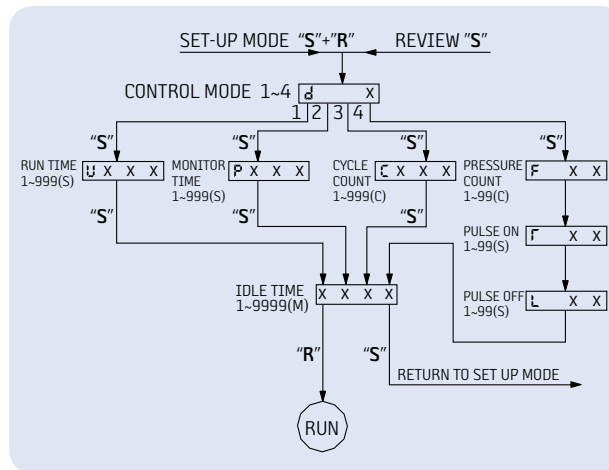

* For lubricators fitted with low level switch

Dimensional Schematics

Measurements shown in millimeters.

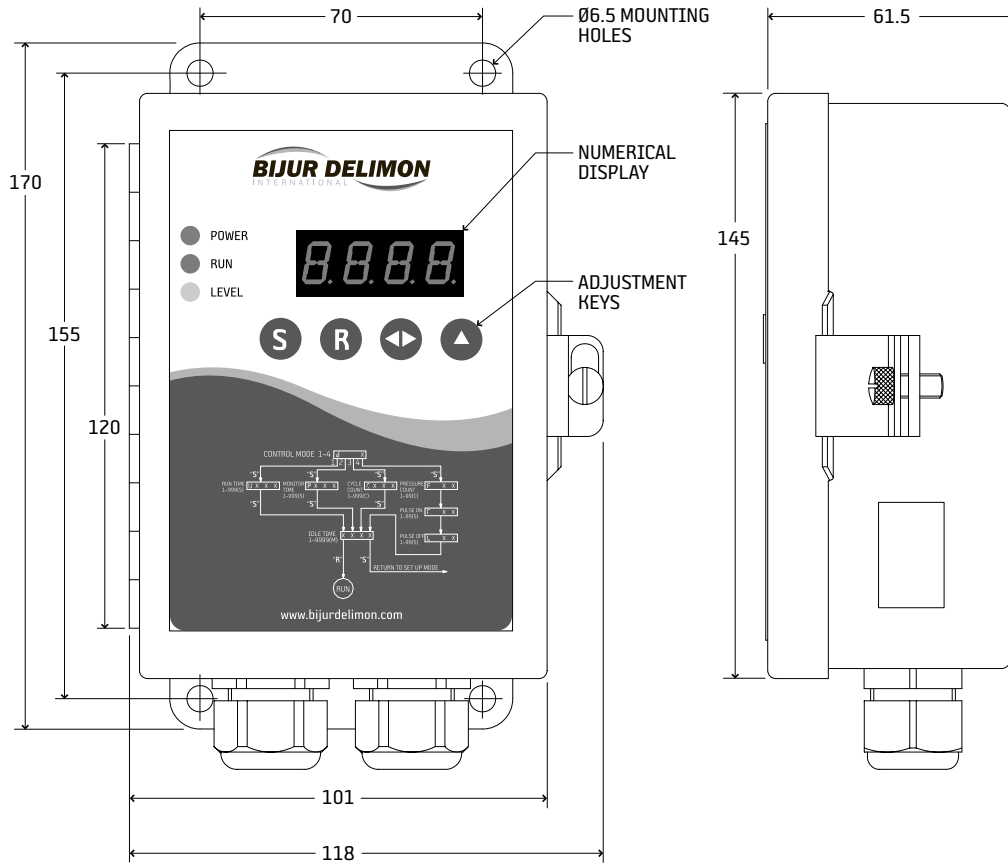

BIJUR DELIMON INTERNATIONAL

(919) 465 4448 LOCAL
(800) 631 0168 TOLL-FREE
(919) 465 0516 FAX

WWW.BIJURDELIMON.COM

2100 Gateway Centre Blvd., Suite 109
Morrisville, NC 27560